

Component Power

for Laser and Optoelectronics Applications



Vicor's Experience

Vicor's modular power components and complete power systems are used by customers throughout the world to create solutions for a wide range of optoelectronics and laser products for industrial, transportation, medical, defence and other markets.

Optoelectronics is a rapidly-growing field that demands high-quality power supplies that deliver large currents with high efficiency. In addition to excellent electrical performance, the supplies must be able to cope with harsh environments in outdoor display applications. Converters must be compact, efficient and able to deliver high currents to the load. Vicor's range of DC-DC converters, AC-DC power supplies and accessory products are ideal for these applications. We help customers develop applications including energy-efficient solid state lighting; LED displays; backlighting for LCDs; and military, medical and industrial laser systems.

Vicor's long, successful record supporting customers in these demanding markets, our understanding of the technical requirements, and our comprehensive range of modular converters and accessory products makes Vicor the ideal choice for your next design.

Application Examples



3D Laser Engraving — Vicor modules provide the high power density and precise current regulation needed to accurately control laser diodes. This application uses the laser diodes to engrave 3D images in decorative glass cubes by using a laser to heat a spot within the glass to create a micro-explosion that forms a white dot.

Airborne Military Laser — The high-quality AC-DC suppliers from Vicor's subsidiary, Westcor, are ideal for high-power laser applications, providing multiple configurable high-current outputs from a 3-phase input and generating minimal electronic noise. The Westcor supplies offer outstanding power density, enabling the system to be fitted in existing aircraft.



Industrial Lasers — Vicor's PFC MegaPAC AC-DC converters offer a power supply solution for industrial laser applications including labelling, engraving and cutting. Power factor correction ensures the system meets regulations, field configurability allows the system to be optimised for each customer's needs, and the output trim ensures that the laser is driven with exactly the right current.

Passenger Information Displays — Vicor's rugged modules are ideal for use in harsh environments, such as outdoor passenger information displays for bus services. Their wide operating temperature and high MTBF ensures the systems keep working; the small size and high power density allow the displays to be compact; and the high efficiency minimises cooling challenges.



Professional Video Walls — Vicor's converters are ideal for applications that need power supplies that can deliver high currents and fast current transients at relatively low voltages, whilst using sense compensation to ensure an accurately regulated voltage is delivered. These applications include huge video walls seen at large events, particularly the new LED-based displays.

Laser Show Projectors — Vicor's rugged, compact and light-weight modules are ideal for portable laser show projectors that are used for concerts and other events. The high power density and high efficiency ensures the system remains compact and portable, whilst minimising the heat dissipation challenges.

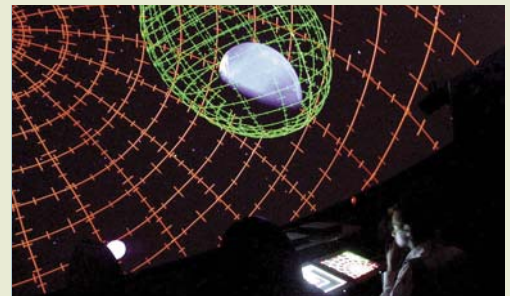

LED Backlights for LCDs — Vicor's VI-Chip family are very compact and highly efficient converters that are ideal to supply high-current, low-voltage power for large format LCD screen backlighting. BCMs are small enough to step-down a 48 V supply to 5 V locally, simplifying the current distribution for a large backlight array.

LED Screen Flooring — The high efficiency and compact size of Vicor DC-DC modules is ideal for the creation of modular LED screen floors. This flooring is used in TV studios, exhibitions, conventions and clubs to create stunning floor displays.



High-Efficiency Solid-State Lighting — LEDs are increasingly used for high-efficiency lighting in a wide range of applications. The Vicor DC-DC converter provides the constant current with high control accuracy that is needed to drive LED arrays using a "lossless" differential current-sense and controlling amplifier into PRM's voltage control pin. One converter can be configured to control any colour or size of LED.

Vicor's Products

Vicor offers component power solutions from watts to kilowatts that are ideal for optoelectronics and laser applications. Vicor's broad portfolio of products offers many advantages for these systems, including high power density, compact size, low noise, wide input range, constant current output and rugged construction.

Meeting the Requirements

Requirement	Met By
Small size and low profile	High power density of up to 7.3 W/cm ³
High efficiency	Maxi / Mini / Micro efficiency in excess of 88%
Displays need low profile supplies to ensure flat construction	Total module height, over PC board is only 12 mm
Conduction cooling due to limited space, and to reduce acoustic noise	Aluminum baseplate allows chassis / wall mounting of the power supply
Wide output trim range, to allow adjustment of output current	Maxi, Mini and Micro modules offer a trim range of 10% to 110%, making it easy to convert the bricks into constant current sources. PRM can act as constant current source
Multiplexed LED matrixes require impulsive current during switching	Fast transient response times of less than 200 μ s
Support for both battery and mains power sources	Broad choice of input voltage ranges. Easy to implement supply that accepts multiple input sources
Low electromagnetic emissions	ZCS resonant converter topology intrinsically produces low emissions
Low operating temperature for outdoor applications	Operating temperature to -55°C, storage to -65°C
Watertight	Baseplate cooling capabilities allows mounting within closed, waterproof chassis

Constant Current Circuit for Driving LEDs

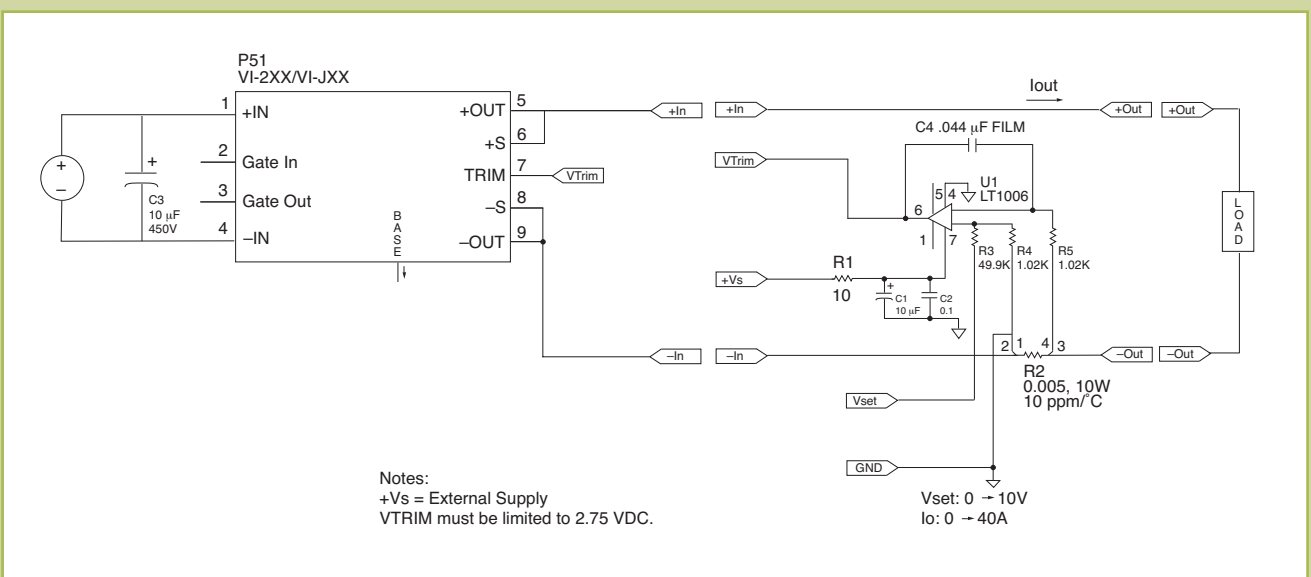

Vicor: Supporting your Design

Vicor has a unique understanding of the challenges that face engineers developing power supply solutions for optoelectronics applications. We offer expert technical support, ranging from applications notes and qualification reports about the environmental testing of our products to on-site assistance from our team of highly qualified field applications engineers. Our technical support team includes engineers that understand how to maximise available board space; simplify thermal design; develop constant current sources; and minimise EMI and noise by selecting the right power supply solution for the application.

For more information visit vicoreurope.com or
Talk to us on **00 800 8426 7000** (international free phone number)

Comprehensive Technical Library

Access technical information related to using Vicor products in optoelectronics online:

Application Notes

Access our comprehensive range of applications notes and other technical documentation at – vicoreurope.com/applicationnotes



Request Our Catalogue

For a full overview of all our products, request a copy from your local office or visit vicoreurope.com/catalogue

Design Exactly the Product You Need...As Standard

Design your own DC-DC converter or configurable power supply to meet your application's exact needs.

PowerBench, Vicor's custom configuration tools is available online at vicoreurope.com/powerbench



vicoreurope.com

Contact Vicor

Vicor France

6, Parc Ariane
Bâtiment "Le Mercure"
78284 Guyancourt Cedex
France

Tel: +33 1 34 52 18 30
Email: vicorfr@vicorpower.com

Vicor Germany

Adalperstraße 29
85737 Ismaning
Germany

Tel: +49 89 962 439 0
Email: vicorde@vicorpower.com

Vicor Italy

Via Milanese, 20
20099 Sesto S. Giovanni
Milano
Italy

Tel: +39 02 2247 2326
Email: vicorit@vicorpower.com

Vicor UK

Coliseum Business Centre
Riverside Way, Camberley
Surrey GU15 3YL
United Kingdom

Tel: +44 1276 678222
Email: vicoruk@vicorpower.com



vicoreurope.com